

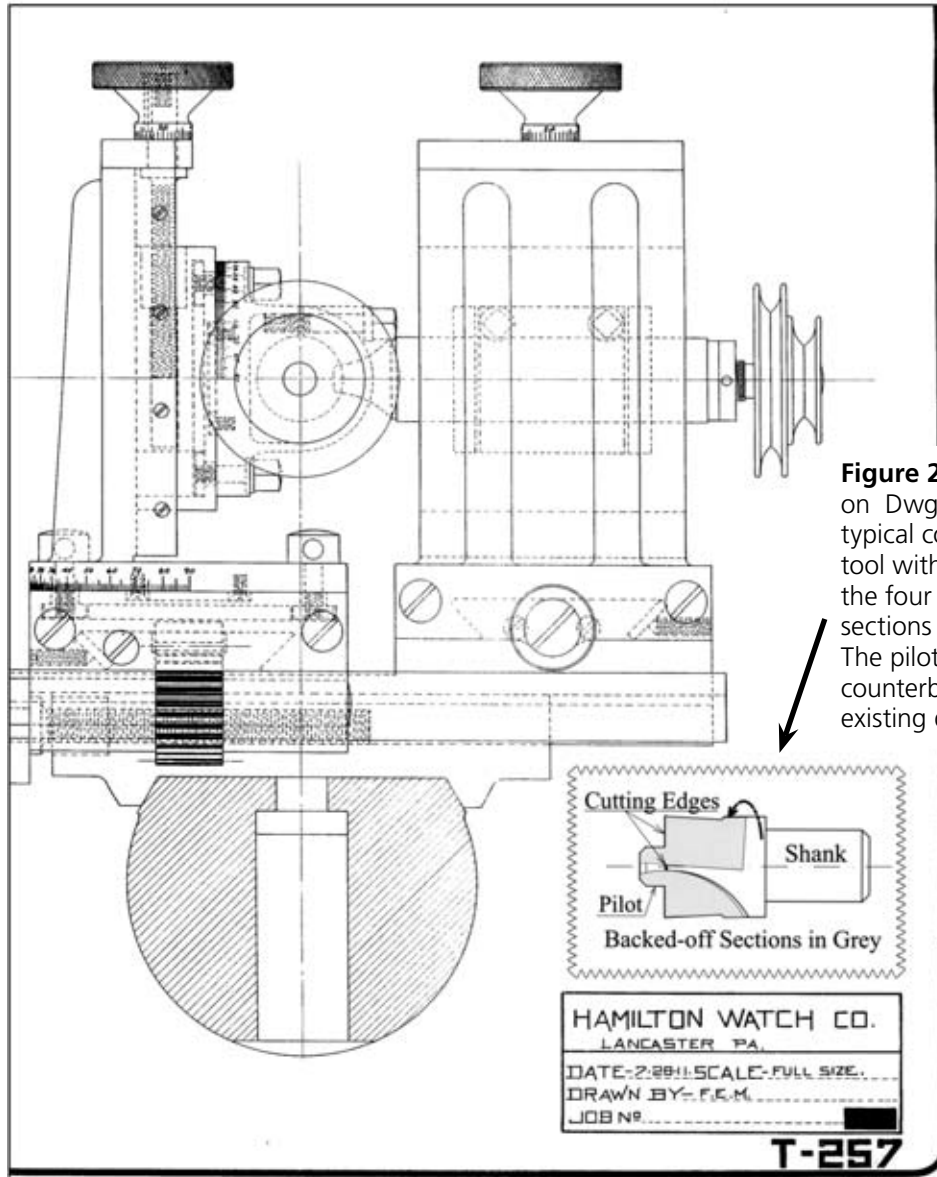

# The National Watch and Clock Museum

By Robert Hostetter, LARC volunteer, and Sharon Gordon, LARC director

## A Hamilton/Illinois Watch tool drawing database update



**Figure 1.** A portion of drawing T-257, dated 7-28-11. The machine was designed to add clearances to counterbores. These clearances provide space for the continuous flow of metal chips from the work area while cutting recesses for screw heads, etc. The size of the complete drawing is 21" x 29" and this portion is approximately one-half scale.

The focus turns to large format drawings as I begin the sixth year of documenting drawings from the Hamilton and Illinois archives. Many of the drawings being processed now are approximately 21" x 29". I mentioned in my last report that the Illinois title blocks lacked enough information to indicate how some individual tools were used. In the early 1900s Hamilton also had not yet adopted an informative title block format or standardized drawing

**Figure 2.** (Overlaid on Dwg. T-257) A typical counterbore tool with two of the four backed-off sections showing. The pilot centers the counterbore in an existing drilled hole.

sizes. I have found drawings made in the early 1930s whose dimensions of 22" x 34" indicate a decision to adopt multiples of the letter-size sheet as a standard.

Currently, drawings made in the early 1900s are being recorded. Figure 1, showing a portion of drawing T-257, looks like a drawing generated by a computer-aided design (CAD) system. But this work was done long before CAD systems were envisioned.

The draftsman (F.E.M.), working in ink with the aid of straight edge, triangle, and compass, traced a scaled drawing done in pencil by the machine designer. It's part of the assembly drawing for a "COUNTER-BORE BACKING OFF MACHINE." In 1911, when this drawing was made, most cutting tools, such as drills, counterbores, and taps, were custom made to suit the size requirements of watch companies, and the quantities required justified building specialized machines to produce these tools.

—Robert Hostetter (PA)

## The National Watch and Clock Museum

### Digital-format information now available for loan on compact discs—thanks to volunteer Tom Anderson

1. *Booklet of Special Barrel Bridge and Dial Engravings*. Scanned from an "autograph" book found in the Hamilton Watch archives. Original scans of various prints associated with special barrel bridge engravings and dials. Original document page size noted at the beginning of the disk. The images are unaltered from the original scans. 43 pages.

2. *1909 Hamilton Watch Company Catalog*. Scanned from the original book found in the Hamilton Watch archives. Digitally enhanced images from the 1909 Hamilton Watch Company catalog, including color covers. This document also describes the various grade watches available in 1909. 27 pages.

3. *1917 Hamilton Watch Company Materials Catalog*. Scanned from the original book found in the Hamilton Watch archives. Digitally enhanced images from the 1917 Hamilton Watch Company Materials catalog. 39 pages.

4. *1920 Hamilton Watch Company Materials Catalog*. Scanned from the original book found in the Hamilton archives. Digitally enhanced images from the 1920 Hamilton Watch Company Material Catalog. 49 pages.

5. *1935 Hamilton Watch Materials Catalog*. Scanned from the original book found in the Hamilton Watch archives. Includes color covers. 49 pages.

6. *1930 Illinois Watch Materials Supplement Catalog*. Scanned from the original book found in the Hamilton Watch archives. Digitally enhanced images from the 1930 Illinois Watch supplement catalog/division of the Hamilton Watch Company. Covers dials and hands. 11 pages.

7. *1936 Illinois Watch Materials Supplement Catalog*. Scanned from the original book found in the Hamilton Watch archives. Digitally enhanced images of the 1936 Illinois Watch Materials supplement catalog/division of the Hamilton Watch Company. 11 pages.

### Recent Donations

We thank the following individuals and NAWCC Chapters for donating materials to the Library & Research Center: Thomas A. Anderson, Fortunat F. Mueller-Maerki, Bruce Shawkey, NAWCC Chapter 22, and NAWCC Chapter 181. ☒

### New books added to the Lending Library

*Clock and Watchmakers of New South Wales from First Fleet to Federation* by Judy Hose.

*Clockmakers and Watchmakers Operating in the State of Victoria from Settlement to Federation* by Judy Hose.

*Ziegeler—Melbourne's Clockmaker* by Ken Hose.

*Fairbairn's Crests of the Families of Great Britain and Ireland* by James Fairbairn; revised by Laurence Butters.

*Dictionary of Ornament* by Philippa Lewis and Gillian Darley.

*Chronometer Makers of the World*, rev. ed. by Tony Mercer.

*Die Taschenuhren der E. Howard & Co., Boston* by Christian von Büchau.

*An Illustrated Dictionary of Ornament* by Dora Ware and Maureen Stafford.

*Carving Architectural Detail in Wood—The Classical Tradition* by Frederick Wilbur.

**UNITED STATES POSTAL SERVICE® (All Periodicals Publications Except Requester Publications)**

1. Publication Title: **Watch & Clock Bulletin**

2. Issue Frequency: **Bi-Monthly**

3. Complete Mailing Address of Known Office of Publication (Not printer) (Street, city, county, state, and ZIP+4®):  
National Association of Watch and Clock Collectors, Inc.  
514 Poplar St., Lancaster County, Columbia, PA 17512-2130

4. Complete Mailing Address of Headquarters or General Business Office of Publisher (Not printer):  
National Association of Watch and Clock Collectors, Inc.  
514 Poplar St., Columbia, PA 17512-2130

5. Full Names and Complete Mailing Addresses of Publisher, Editor, and Managing Editor (Do not leave blank):  
Publisher (Name and complete mailing address):  
National Association of Watch and Clock Collectors, Inc.  
514 Poplar St., Columbia, PA 17512-2130  
Editor (Name and complete mailing address):  
Diana M. DeLuca  
National Association of Watch and Clock Collectors, Inc.  
514 Poplar St., Columbia, PA 17512-2130  
Managing Editor (Name and complete mailing address):  
Diana M. DeLuca  
National Association of Watch and Clock Collectors, Inc.  
514 Poplar St., Columbia, PA 17512-2130

6. Owner (Do not leave blank. If the publication is owned by a corporation, give the name and address of the corporation immediately followed by the names and addresses of all stockholders owning or holding 1 percent or more of total amount of stock. If not owned by a corporation, give the name and address of the individual owner. If owned by a partnership or other unincorporated firm, give its name and address as well as those of each individual owner. If the publication is published by a nonprofit organization, give its name and address.)  
Full Name: National Association of Watch and Clock Collectors, Inc.  
Complete Mailing Address: 514 Poplar St., Columbia, PA 17512-2130

7. Known Bondholders, Mortgagees, and Other Security Holders Owning or Holding 1 Percent or More of Total Amount of Bonds, Mortgages, or Other Securities. If none, check box  None

8. Tax Status (For completion by nonprofit organizations authorized to mail at nonprofit rates) (Check one)  
 Has Not Changed During Preceding 12 Months (Publisher must submit explanation of change with this statement)  
 Has Changed During Preceding 12 Months (Publisher must submit explanation of change with this statement)

9. Publication Title: **Watch & Clock Bulletin**

10. Issue Date for Circulation Data Below: **August 2010**

11. Extent and Nature of Circulation

	Average No. Copies Each Issue During Preceding 12 Months	No. Copies of Single Issue Published Nearest to Filing Date
a. Total Number of Copies (Net press run)	18,777	17,651
b. Paid Distribution (Sum of 11b(1), 11b(2), 11b(3), and 11b(4))	16,980	16,027
c. Total Paid Distribution (Sum of 11b(1), 11b(2), 11b(3), and 11b(4))	1,194	1,175
d. Total Free or Nominal Rate Distribution (Sum of 11d(1), 11d(2), 11d(3), and 11d(4))	118	97
e. Total Free or Nominal Rate Distribution (Sum of 11d(1), 11d(2), 11d(3), and 11d(4))	18,292	17,299
f. Total Distribution (Sum of 11c and 11e)	230	182
g. Total (Sum of 11a and 11f)	18,527	17,481
h. Copies not Distributed (See instructions to Publishers #4 page #12)	255	170
i. Total (Sum of 11g and h)	18,777	17,651
j. Percent Paid (11b divided by 11a times 100)	90.7	90.9

12. Publication of Statement of Ownership:  
 If the publication is a general publication, publication of this statement is required. Will be printed in the **December 2010** issue of this publication.  Publication not required.

13. Signature and Title of Editor, Publisher, Business Manager, or Owner:  
*Diana M. DeLuca* Editor Oct. 1, 2010

I certify that all information furnished on this form is true and complete. I understand that anyone who furnishes false or misleading information on this form or who omits material or information requested on the form may be subject to criminal sanctions (including fines and imprisonment) and/or civil sanctions (including civil penalties).

PS Form 3526, September 2007 (Page 1 of 2) Instructions Page 2) PSN 7530-01-000-9031 PRIVACY NOTICE: See our privacy policy at www.usps.com